

3001

SMS weld malepart - 316

Nom size	A	B	C	Stock No
1"	25.4	40.0	15.0	3001-5026
1 ½"	38.1	60.0	20.0	3001-5038
2"	50.8	70.0	20.0	3001-5051
2 ½"	63.5	85.0	24.0	3001-5064
3"	76.2	98.0	24.0	3001-5076
4"	101.6	125.0	30.0	3001-5102
4"	101.6	132.0	28.0	3001-5103

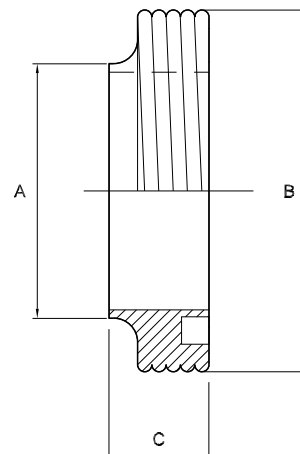

TECHNICAL DATA	
Associated Standards	SMS 1145, SMS 1146
Material	316 Stainless Steel
Material Certification	BS EN 10204/DIN 50049 3.1
Finish	Internal 1.6Ra or better
SMS Fittings Range	Unions, ferrules, blanks, tees, bends, hoseliners, adaptors, concentric & eccentric reducers, Y pieces
Seals	EPDM, Nitrile, Silicone, Viton® (Viton® is a registered trade mark of DuPont Dow Elastomers)
Notes	Dimensions are provided in good faith. Seals must be chosen for required operating medium and temperature
GENERAL CAPABILITIES	
Design and System Fabrication, Hygienic Process Plant, Project Management, In-house Manual and Orbital Welding, Machining, Fabrication and Polishing, Component Customisation	
Full materials certification, weld maps, logs, welder qualifications and weld procedures, pickling, passivation and ferroxyl certification.	

D3001-V03 / ECN 737

CUSTOMISED STAINLESS STEEL SYSTEMS, FABRICATIONS AND COMPONENTS

Axium Process Ltd

Hendy Industrial Estate, Hendy, Swansea, UK SA4 0XP

Tel: +44 (0) 1792 883882

Fax: +44 (0) 1792 886049

Email: info@axiumprocess.com

Web: www.axiumprocess.com



All data is provided in good faith and is subject to change