

**8062**

**Plain-ended swept Y piece 316L**

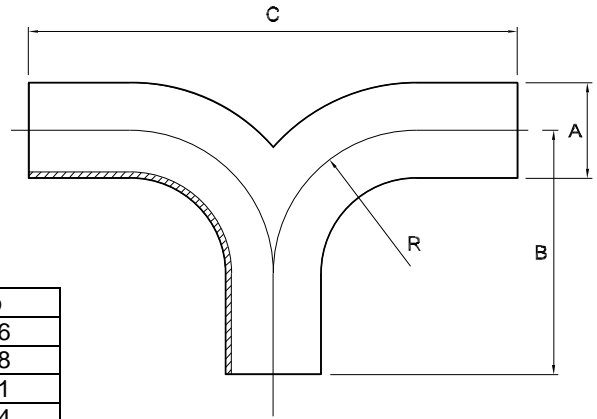

Nom size	A	B	C	R	Stock No
1"	25.4	65.0	130.0	38.1	8062-6026
1 1/2"	38.1	85.0	170.0	57.2	8062-6038
2"	50.8	110.0	220.0	76.2	8062-6051
2 1/2"	63.5	135.0	270.0	95.3	8062-6064
3"	76.2	155.0	310.0	114.3	8062-6076
4"	101.6	195.0	390.0	152.4	8062-6102

TECHNICAL DATA	
Associated Standards	BS 4825 : Part 2 : 1991, ASTM A269, ASTM A270, ASTM A312
Material	316L Stainless Steel
Material Certification	BS EN 10204/DIN 50049 3.1 for all wetted parts
Finish	Welds ground ID & OD, Polished 0.8Ra ( 0.4 Ra available)
Tolerance	+/- 1.0mm
Plain-Ended Fittings Range	Tees, 90°, 45° & 180° bends, hositails, concentric & eccentric reducers, Y pieces, Crosses
Notes	Dimensions are provided in good faith. Seals must be chosen for required operating medium and temperature
GENERAL CAPABILITIES	
Design and System Fabrication, Hygienic Process Plant, Project Management, In-house Manual and Orbital Welding, Machining, Fabrication and Polishing, Component Customisation	
Full materials certification, weld maps, logs, welder qualifications and weld procedures, pickling, passivation and ferroxyl certification.	

D8062-V02 / ECN 730

**CUSTOMISED STAINLESS STEEL SYSTEMS, FABRICATIONS AND COMPONENTS**

**Axium Process Ltd**

Hendy Industrial Estate, Hendy, Swansea, UK SA4 0XP  
 Tel: +44 (0) 1792 883882  
 Fax: +44 (0) 1792 886049  
 Email: [info@axiumprocess.com](mailto:info@axiumprocess.com)  
 Web: [www.axiumprocess.com](http://www.axiumprocess.com)



All data is provided in good faith and is subject to change