

BSP female elbow 90 deg - 316

Nom size	A	B	Max Op @ 150°C Pressure (bar)	Stock No
1/8"	17.4	19.0	10	6109-5003
1/4"	17.4	19.0	10	6109-5006
3/8"	20.6	23.8	10	6109-5009
1/2"	27.0	28.5	10	6109-5013
3/4"	33.3	34.9	10	6109-5019
1"	39.6	39.6	10	6109-5026
1 1/4"	46.0	50.8	10	6109-5031
1 1/2"	52.3	57.1	10	6109-5038
2"	65.0	69.8	10	6109-5051
2 1/2"	74.6	88.9	10	6109-5064
3"	87.3	101.6	10	6109-5076
4"	112.7	127.0	10	6109-5102

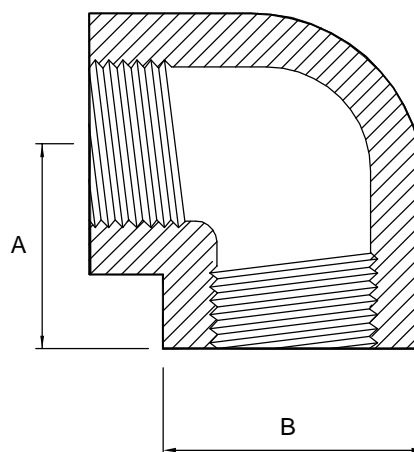

Technical Data:

- | | |
|---|------------------------|
| • Material: 316 Stainless Steel | • Tolerance: +/- 0.5mm |
| • Finish: Descaled | • Seals: PTFE Tape |
| • Pressure/Temperature: See above | |
| • Associated standards: BS 1740, BS1387 | |
| • Applications : Non-hygienic | |

- We stock a comprehensive range of BSP fittings including unions, ferrules, bends, tees, reducers, hoseliners and adaptors
- Components can be fabricated to customer specification
- Fabrication capabilities include frameworks, skid mounted systems, manifolds, jacketed assemblies, adaptors, flowplates and spool pieces.
- In-house services include machining, welding, fabrication, polishing.

D6109 – V01

NOTES

FORM No:FM002-V02

Axiom Process Ltd
Hendy Industrial Estate
Hendy, Swansea
SA4 0XP UK

- Dimensions are provided in good faith but maybe subject to change
- Seals must be chosen for required operating medium & temperature

(T) +44 (0)1792 883 882
 (F) +44 (0)1792 886 049
 (E) info@axiumprocess.com
 (W) www.axiumprocess.com