

6107

## BSPT hex nipple - 316

Nom size BSPT	A	B	Max Op @ 150°C Pressure (bar)	Stock No
1/8"	20.6	13.3	10	6107-5003
1/4"	30.1	15.2	10	6107-5006
3/8"	30.1	20.8	10	6107-5009
1/2"	38.1	23.3	10	6107-5013
3/4"	41.2	28.0	10	6107-5019
1"	50.8	35.3	10	6107-5026
1 1/4"	58.7	47.2	10	6107-5031
1 1/2"	60.3	52.0	10	6107-5038
2"	68.2	63.5	10	6107-5051
2 1/2"	79.3	79.3	10	6107-5064
3"	89.0	92.0	10	6107-5076

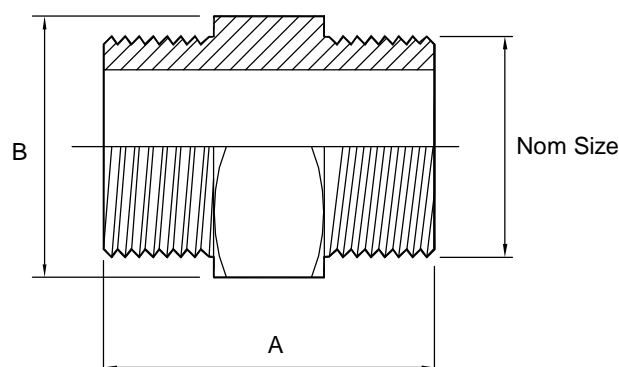

### Technical Data:

- Material: 316 Stainless Steel
- Finish: Descaled
- Pressure/Temperature: See above
- Associated standards: BS1740, BS1387
- Applications : Non-hygienic
- Tolerance: +/- 0.5mm
- Seals: PTFE Tape

- We stock a comprehensive range of BSP fittings including unions, ferrules, bends, tees, reducers, hoseliners and adaptors
- Components can be fabricated to customer specification
- Fabrication capabilities include frameworks, skid mounted systems, manifolds, jacketed assemblies, adaptors, flowplates and spool pieces.
- In-house services include machining, welding, fabrication, polishing.

D6107 – V01

### NOTES

FORM No:FM002-V02

Axium Process Ltd  
Hendy Industrial Estate  
Hendy, Swansea  
SA4 0XP UK

- Dimensions are provided in good faith but maybe subject to change
- Seals must be chosen for required operating medium & temperature

(T) +44 (0)1792 883 882  
 (F) +44 (0)1792 886 049  
 (E) [info@axiumprocess.com](mailto:info@axiumprocess.com)  
 (W) [www.axiumprocess.com](http://www.axiumprocess.com)