

BSP female hex union - 316

Nom size	A	B	C	Max Op @ 150°C Pressure (bar)	Stock No
1/8"	27.9	22.2	34.9	10	6006-5003
1/4"	30.4	25.4	36.5	10	6006-5006
3/8"	33.0	28.5	42.2	10	6006-5009
1/2"	37.5	31.7	47.6	10	6006-5013
3/4"	52.3	35.0	50.8	10	6006-5019
1"	57.1	35.0	57.1	10	6006-5026
1 1/4"	69.8	47.6	63.5	10	6006-5031
1 1/2"	76.2	55.3	71.4	10	6006-5038
2"	92.0	66.5	77.7	10	6006-5051
2 1/2"	114.3	85.6	82.5	10	6006-5064
3"	139.7	95.2	109.5	10	6006-5076

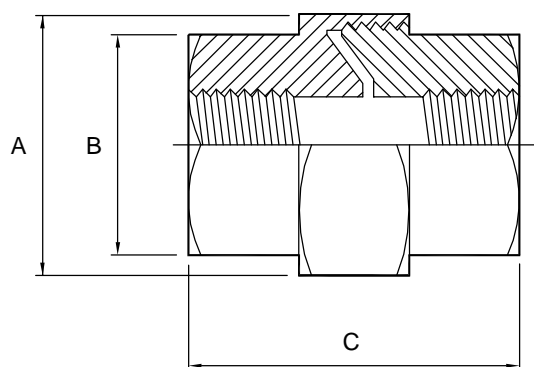

Technical Data:

- Material: 316 Stainless Steel
- Finish: Descaled
- Pressure/Temperature: See above
- Associated standards: BS 1740, BS1387
- Applications : Non-hygienic
- Tolerance: +/- 0.5mm
- Seals: PTFE Tape

- We stock a comprehensive range of BSP fittings including unions, ferrules, bends, tees, reducers, hoseliners and adaptors
- Components can be fabricated to customer specification
- Fabrication capabilities include frameworks, skid mounted systems, manifolds, jacketed assemblies, adaptors, flowplates and spool pieces.
- In-house services include machining, welding, fabrication, polishing.

D6006 – V01

NOTES

FORM No:FM002-V02

Axium Process Ltd
Hendy Industrial Estate
Hendy, Swansea
SA4 0XP UK

- Dimensions are provided in good faith but maybe subject to change
- Seals must be chosen for required operating medium & temperature

(T) +44 (0)1792 883 882
 (F) +44 (0)1792 886 049
 (E) info@axiumprocess.com
 (W) www.axiumprocess.com