

Clamp bend 90 deg Short 316L

Nom size	L	R	Rad D	Max Recommended Op Pressure (bar) @ 150°C	Stock No
1"	65.5	38.1	1.5D	10	5075-6026
1½"	85.5	57.2	1.5D	10	5075-6038
2"	110.5	76.2	1.5D	10	5075-6051
2½"	135.5	95.3	1.5D	10	5075-6064
3"	155.5	114.3	1.5D	10	5075-6076
4"	194.0	152.4	1.5D	10	5075-6102

92° and 88° options available

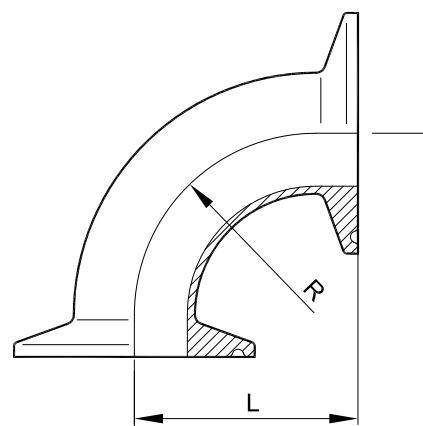

Technical Data:

- | | |
|---|---|
| <ul style="list-style-type: none"> Material: 316L Stainless Steel Finish: Descaled ID, Polished 0.8Ra OD (0.4Ra available) Pressure/Temperature: See above (temp according to seal material) Associated standards: BS 4825 : Part 3 : 1991 (1" to 4" inclusive) | <ul style="list-style-type: none"> Tolerance: +/- 0.5mm Seals: EPDM, Nitrile, Silicone, Platinum Cured Silicone, Encapsulated & Solid PTFE, Viton®
<small>Viton® is a registered trademark of DuPont Dow Elastomers</small> |
| <ul style="list-style-type: none"> Applications : Clamp fittings are suitable for beverage, fine chemical, pharmaceutical and biotech applications, where crevice free conditions are critical. | |

- We stock a comprehensive range of clamp fittings including unions, ferrules, bends, tees, reducers, hoseliners and adaptors
- Components can be fabricated to customer specification
- Fabrication capabilities include frameworks, skid mounted systems, manifolds, jacketed assemblies, adaptors, flowplates and spool pieces.
- In-house services include machining, welding, fabrication, polishing.

D5075 - V01

NOTES

- Dimensions are provided in good faith but maybe subject to change
- Seals must be chosen for required operating medium & temperature