

4085-01

DIN Imp eccentric reducers - M/F - 316 DIN11851

Nom size fitting		A	B	C	Max Op Pressure (bar) @ 20°C	Stock No
Larger	Smaller					
1 1/2"	1"	25.4	12.7	68.0	10	4001-5038-026
2"	1"	25.4	19.1	57.0	10	4001-5051-026
2"	1 1/2"	38.1	25.4	96.0	10	4001-5051-038
2 1/2"	1"	38.1	19.1	97.0	10	4001-5064-026
2 1/2"	1 1/2"	38.1	25.4	72.0	10	4001-5064-038
2 1/2"	2"	50.8	12.7	116.0	10	4001-5064-051
3"	1"	50.8	19.1	103.0	10	4001-5076-026
3"	1 1/2"	50.8	25.4	88.0	10	4001-5076-038
3"	2"	50.8	38.1	74.0	10	4001-5076-051
3"	2 1/2"	63.5	25.4	119.0	10	4001-5076-064
4"	1 1/2"	63.5	38.1	91.0	10	4001-5102-038
4"	2"	63.5	50.8	81.0	10	4001-5102-051
4"	2 1/2"	76.2	25.4	143.0	10	4001-5102-064
4"	3"	76.2	38.1	117.0	10	4001-5102-076

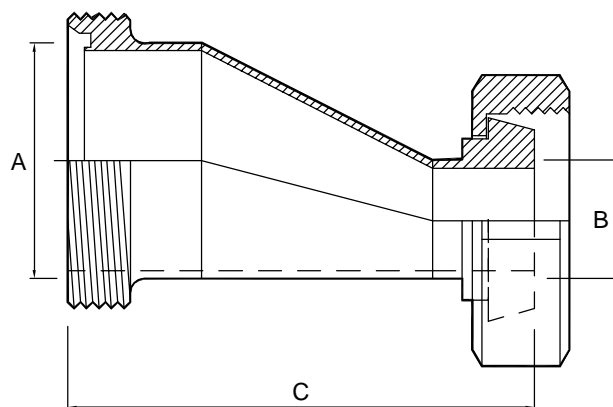

Technical Data:

- Material: 316 Stainless Steel
- Finish: 0.8RA or better
- Pressure/Temperature: See above (temp according to seal material)
- Associated standards: DIN 11851, DIN, 11850, DIN 11864, and DIN 11887
- Applications : DIN fittings are suitable for most hygienic applications, particularly in the food, beverage and pharmaceutical industries
- Tolerance: +/- 0.5mm
- Seals: EPDM, Silicone, Viton®, Nitrile, & Solid PTFE

- We stock a comprehensive range of DIN fittings both imperial and metric, including maleparts, liners, nuts, bends, hoseliners, tees, and reducers
- Components can be fabricated to customer specification
- Fabrication capabilities include frameworks, skid mounted systems, manifolds, jacketed assemblies, adaptors, flowplates and spool pieces.
- In-house services include machining, welding, fabrication, polishing.

4085-01-V01

NOTES

- Dimensions are provided in good faith but maybe subject to change
- Seals must be chosen for required operating medium & temperature

FORM No:FM002-V02

Axium Process Ltd
Hendy Industrial Estate
Hendy, Swansea
SA4 0XP UK

☎ +44 (0)1792 883 882
☎ +44 (0)1792 886 049
✉ info@axiumprocess.com
🌐 www.axiumprocess.com