

IDF eccentric reducers, M/F - 316 BS4825

Nom size fitting		A	B	C	Max Op @ 20°C Pressure (bar)	Stock No
Larger	Smaller					
1 1/2"	1"	38.1	25.4	70.0	10	2085-5038-026
2"	1"	50.4	25.4	90.0	10	2085-5051-026
2"	1 1/2"	50.4	38.1	81.0	10	2085-5051-038
2 1/2"	1"	63.5	25.4	111.0	10	2085-5064-026
2 1/2"	1 1/2"	63.5	38.1	117.0	10	2085-5064-038
2 1/2"	2"	63.5	50.4	88.0	10	2085-5064-051
3"	1"	76.2	25.4	138.0	10	2085-5076-026
3"	1 1/2"	76.2	38.1	111.0	10	2085-5076-038
3"	2"	76.2	50.4	123.0	10	2085-5076-051
3"	2 1/2"	76.2	63.5	83.0	10	2085-5076-064
4"	1 1/2"	101.6	38.1	167.5	10	2085-5102-038
4"	2"	101.6	50.4	147.5	10	2085-5102-051
4"	2 1/2"	101.6	63.5	120.5	10	2085-5102-064
4"	3"	101.6	76.2	126.5	10	2085-5102-076

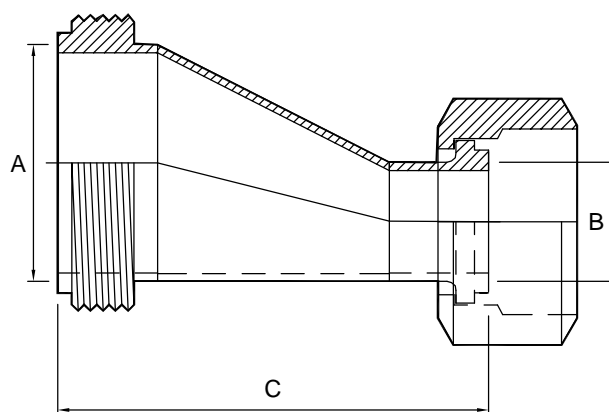

Technical Data:

- Material: 316 Stainless Steel
- Finish: 0.8RA or better
- Pressure/Temperature: See above (temp according to seal material)
- Associated standards: BS 4825 : Part 4 : 1991 (1" to 4" inclusive)
- Applications : Used widely throughout the dairy industry
- Tolerance: +/- 0.5mm
- Seals: EPDM, Silicone, Viton®, Nitrile, & Solid PTFE

- We stock a comprehensive range of IDF fittings including maleparts, liners, nuts, blanks, seals, blank nut and chains, bends, tees, hoseliners, and spanners
- Components can be fabricated to customer specification
- Fabrication capabilities include frameworks, skid mounted systems, manifolds, jacketed assemblies, adaptors, flowplates and spool pieces.
- In-house services include machining, welding, fabrication, polishing.

2085-V01

FORM No:FM002-V02

NOTES

- Dimensions are provided in good faith but maybe subject to change
- Seals must be chosen for required operating medium & temperature

Axium Process Ltd
Hendy Industrial Estate
Hendy, Swansea
SA4 0XP UK

 +44 (0)1792 883 882
 +44 (0)1792 886 049
 info@axiumprocess.com
 www.axiumprocess.com