

IDF malepart - 316 BS4825

Nom size	A	B	C	Max Op Pressure (bar) @ 20°C	Stock No
1"	25.7	29.2	21.5	10	2001-5026
1½"	38.4	42.7	21.5	10	2001-5038
2"	51.1	56.2	21.5	10	2001-5051
2½"	63.8	69.9	21.5	10	2001-5064
3"	76.5	82.6	21.5	10	2001-5076
4"	101.9	111.1	30.0	10	2001-5102

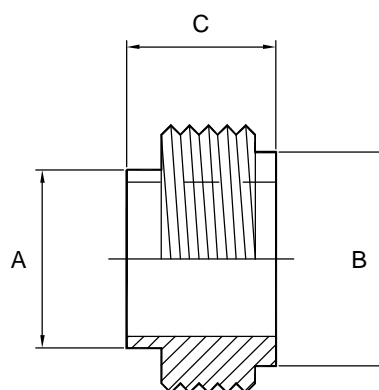

Technical Data:

- Material: 316 Stainless Steel
- Finish: 0.8RA or better
- Pressure/Temperature: See above (temp according to seal material)
- Associated standards: BS 4825 : Part 4 : 1991 (1" to 4" inclusive)
- Applications : Used widely throughout the dairy industry
- Tolerance: +/- 0.5mm
- Seals: EPDM, Silicone, Viton®, Nitrile, & Solid PTFE

- We stock a comprehensive range of IDF fittings including liners, nuts, blanks, seals, blank nut and chains, bends, tees, hoseliners, spanners and reducers
- Components can be fabricated to customer specification
- Fabrication capabilities include frameworks, skid mounted systems, manifolds, jacketed assemblies, adaptors, flowplates and spool pieces.
- In-house services include machining, welding, fabrication, polishing.

2001-V01

NOTES

Axium Process Ltd
Hendy Industrial Estate
Hendy, Swansea
SA4 0XP UK

- Dimensions are provided in good faith but maybe subject to change
- Seals must be chosen for required operating medium & temperature

(T) +44 (0)1792 883 882
 (F) +44 (0)1792 886 049
 (E) info@axiumprocess.com
 (W) www.axiumprocess.com

FORM No:FM002-V02